

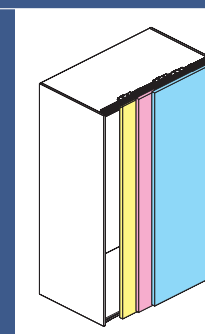

Easy mounting from top to bottom
 Montaggio facile dall'alto al basso
 Montage facile de haut en bas
 Einfache Montage von Oben
 Montaje simple de arriba hacia abajo
 Facilidade de montagem , de cima para baixo
 Легкая сборка шкафа

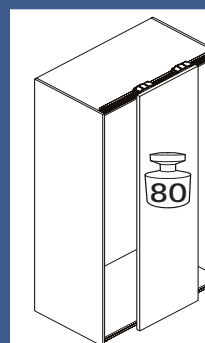

Available for 2 and 3 door applications
 Disponibile versione 2 o 3 porte
 Disponibles versions pour 2 et 3 portes
 Für 2 oder 3 Türen lieferbar
 Disponibles versiones para 2 o 3 puertas
 Disponível em versões para 2 e 3 portas
 Возможно установить 2 и 3 дверки



High load capacity (80 kg)
 Alta portata (80 kg)
 Haute charge dynamique (80 Kg)
 Für Türen bis 80 kg
 Alta capacidad de carga (80 kg)
 Alta capacidade de carga(80kg)
 Максимальная нагрузка (80 кг)



Optimal for kitchen, living room, bedroom and bath furniture
 Ideale per mobili da cucina, salotto, camera e bagno
 Idéale pour les meubles de cuisine, de salons, de chambre ou de salles de bains
 Geeignet für Küchen-, Wohn-, Schlaf- und Badezimmermöbel
 Ideal para muebles de cocina, baño, dormitorio y salón
 Ideal para móveis de cozinha, sala , dormitorio e banheiro
 Оптимально использовать для кухни, гостиной, спальни и мебели для ванных комнат



Exclusive patented "no derail" system
 Meccanismo esclusivo brevettato "anti-deragliamento"
 Système exclusif et breveté "anti-déraillement"
 Exklusiv Patent "No Derail"
 Sistema "anti-descarrilamiento" exclusivo y patentado
 Exclusivo e patenteado sistema "anti - descarrilhamento"
 Эксклюзивная, запатентованная система против соскальзывания



Extremely silent mechanism
 Meccanismo estremamente silenzioso
 Système très silencieux
 Laufruhig
 Mecanismo muy silencioso
 Mecanismo extremamente silencioso
 Абсолютно бесшумный механизм

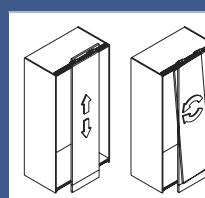

Easily adjustable
 Regolazione semplice
 Réglage facile
 Einfache Justierung
 Facilidad de ajuste
 Facilidade de ajuste
 Легкая регулировка



100% Italian Design
 Design italiano al 100%
 100% design italien
 100% italienisches Design
 Diseño italiano al 100%
 100% Design italiano
 100% итальянский дизайн



New exclusive air dampers for upper and lower tracks (tested up to 50,000 cycles)
 Nuovo esclusivo sistema soft-closing per binario superiore e inferiore (testato fino a 50.000 cicli)
 Nouveau exclusif amortisseur (garanti jusqu'à 50,000 cycles) pour rail inférieur et supérieur



Mit Luftdämpfung für oberes und unteres Profil "NEU"
 Nuevo exclusivo amortiguador de aire (testado hasta 50.000 ciclos) para carril inferior y superior
 Novo e exclusivo sistema soft-closing para carrinho superior e inferior (testado a 50.000 ciclos)
 Новые эксклюзивные воздушные амортизаторы для верхней и нижней направляющих (прошли тест более чем на 50000 циклов)

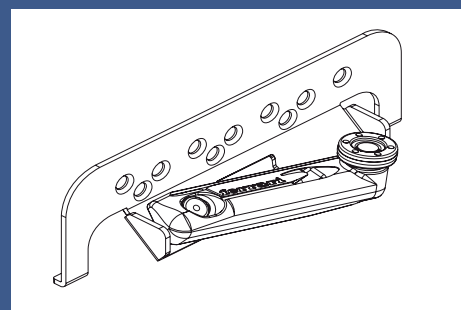

Silent lower wheels made of bicomponent
 Ruote inferiori silenziose in bicomponente
 Galets inférieurs silencieux, en bicomponent
 Laufruhige untere Führung - Laufrad aus 2 Komponenten
 Ruedas inferiores silenciosas de bicomponente
 Silenciosas roldanas inferiores fabricadas em bicomponentes
 Бесшумные нижние ролики, изготовленные из бикомпонентов



Elite

Sliding Door Fitting
 Sistema per ante scorrevoli
 Ferrure de portes coulissantes
 Schiebetür-Beschlag
 Herraje de puertas correderas
 Sistema para portas de correr
 Направляющие для раздвижные дверей



PREMOCS

MIXAL

it ferrari

A. Ferrari S.p.A. - Italia
 Tel. +39 039 5900
 Fax +39 039 5900222
 Internet: www.ferrarispa.it

ferrari
 the heart of furniture